

ECN	REV	DESCRIPTION	DATE	APPROVED

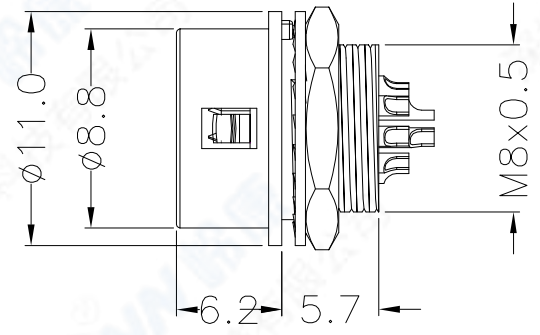

Recommended mounting hole

Mounting hole dimension shown here is tight by hexagon nut from back side.

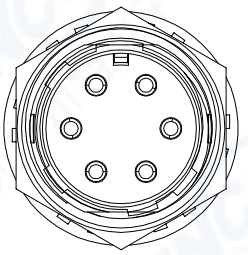
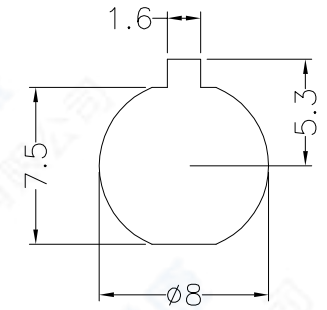

Part number GL10 A -7 R -6 P

Series name _____
 Type A:Low-cost model _____
 Shell size:Plug mating part outside diameter in mm _____
 Shell type P:Plug J:Jack R:Receptacle _____
 Number of contacts _____
 Type of terminal P:Male terminal S:Female terminal _____

技术特性/Technical Characteristics

1. 寿命/Durability: >500 mate/unmate cycles
2. 额定电流/Current rating: 2A
3. 接触电阻/Contact resistance:10mΩ
4. 绝缘电阻/Insulation resistance: 100MΩ
5. 温度等级/Rated Temperature: -20°C, +80°C
6. 盐雾/Corrosion Resistance: Salt spray test>48h

Shell size	7 size		
Contact arrangement			
NO. of pins	4	5	6

5	公针/Pin :黄铜镀金/Brass gold plated
4	绝缘体/Insulator:PA66+GF, Black
3	垫圈/Locking washer: 不锈钢/Stainless Steel
2	六角螺母/Hexagonal nut: 黄铜镀镍/Brass,Nickel plated
1	外壳/Shell:锌合金镀镍/Zinc alloy Nickel Plated
ITEM	SPECIFICATION

	SCALE	TOLERANCES ARE:	
	F	DECIMALES	ANGLES
SHEET	DIMENSION	· X±0.3	±
1 OF 1	MM	· XX±0.15	
DWG NO.	REV.	APPROVALS	DATE
	A0	APPROVED:	
		CHECKED:	
		CHECKED:	
		DRAWN: pengsen	10/23/2021

TITLE: Receptacle(Solder type)	
PART NO. GL10A-7R-6P	REV. *
L inconn E lc Tech C o.,L TD	

由 Autodesk 教育版产品制作

由 Autodesk 教育版产品制作