

ECN	REV	DESCRIPTION	DATE	APPROVED

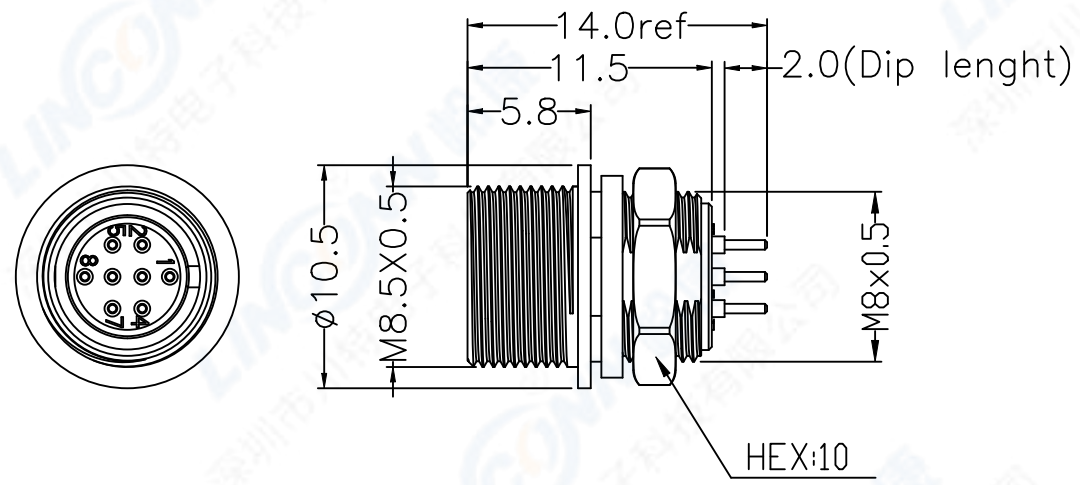

Recommended mounting hole

Mounting hole dimension shown here is tight by hexagon nut from back side.
 Note: The Δ mark indicates the engagement guide key position

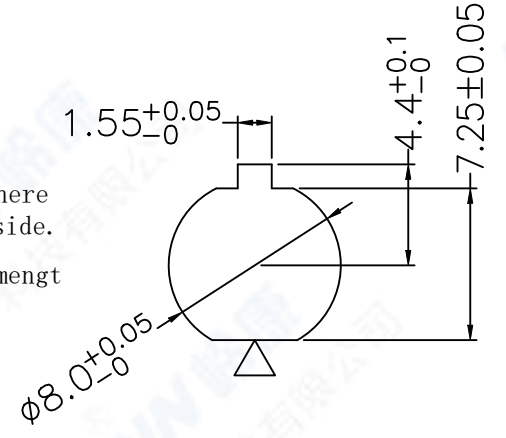

Part number

GL25-7TR-8SA

Model: Indicates the HR25 Series

Shell size: Indicates the outer diameter of the engaging portion of the Plug

Classification of lock mechanism: Indicated as described below
 T: Screw lock system No symbol: Push-pull lock system

Classification of shell P: Plug J: Jack R: Receptacle

Number of contacts

Form of contacts: As described below
 P: Male contacts S: Female contacts

Type of contacts: The wiring system used or the type of contacts are classified in alphabetical order:

- Example None: Solder termination
- C: Crimp-style contacts
- A: PCB dip termination

Shell size	7 size		
Receptacle Dip Post Configuration Dimensions			
NO. of pins	4	6	8
Withstand voltage	100V AC for 1minute		
Current capacity	1A		
Contact resistance	30mΩ		

5	母针/Female pin: 磷铜镀金/Phosphor copper, gold plated
4	绝缘体/Insulator: PA66+GF, Black
3	垫圈/Locking washer: 不锈钢/Stainless Steel
2	六角螺母/Hexagonal nut: 黄铜镀镍/Brass, Nickel plated
1	外壳/Shell: 锌合金镀镍/Zinc alloy Nickel Plated

	SCALE	TOLERANCES ARE:
SHEET	F	DECIMALES
1 OF 1	DIMENSION	ANGLES
DWG NO.	MM	· X ± 0.3
GL25	REV.	· XX ± 0.15
	A0	

APPROVALS	DATE
APPROVED:	
CHECKED:	
CHECKED:	
DRAWN:	

TITLE: Receptacle(Dip type)	
PART NO. GL25-7TR-8SA	REV. *
Linconn Elc Tech Co.,LTD	

ITEM	SPECIFICATION
------	---------------