

ECN	REV	DESCRIPTION	DATE	APPROVED

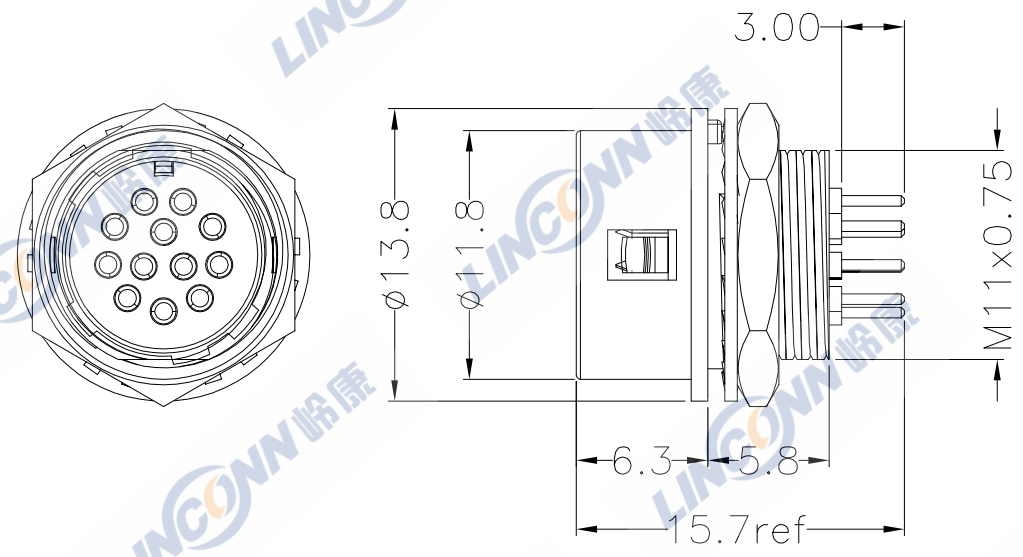

Recommended mounting hole
 Mounting hole dimension shown here is tight by hexagon nut from back side.

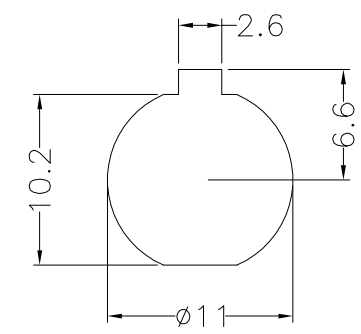

Part number GL10 A -10 R -12 P A

Series name _____
 Type A:Low-cost model _____
 Shell size:Plug mating part outside diameter in mm _____
 Shell type P:Plug J:Jack R:Receptacle _____
 Number of contacts _____
 Type of terminal P:Male terminal S:Female terminal _____
 A:PCB dip termination _____

技术特性/Technical Characteristics

- 1.寿命/Durability: >500 mate/unmate cycles
- 2.额定电流/Current rating: 2A
- 3.耐电压/Withstanding voltage:AC300V for a minute
- 4.接触电阻/Contact resistance:10mΩ
- 5.绝缘电阻/Insulation resistance: 100MΩ
- 6.温度等级/Rated Temperature: -20°C,+80°C
- 7.盐雾/Corrosion Resistance: Salt spray test>48h

Shell size	10 size	
Receptacle Dip Post Configuration Dimensions		
NO. of pins	10	12

5	公针/Pin :黄铜镀金/Brass gold plated
4	绝缘体/Insulator:PA66+GF, Black
3	垫圈/Locking washer: 不锈钢/Stainless Steel
2	六角螺母/Hexagonal nut: 黄铜镀镍/Brass, Nickel plated
1	外壳/Shell: 锌合金镀镍/Zinc alloy Nickel Plated
ITEM	SPECIFICATION

	SCALE	TOLERANCES ARE: DECIMALES ANGLES	
	F	· X±0.3 · XX±0.15	
SHEET	DIMENSION	APPROVALS	DATE
1 OF 1	MM	APPROVED:	
DWG NO.	REV.	CHECKED:	
	A0	CHECKED:	
		DRAWN: pengsen	10/23/2021

TITLE: Receptacle (Dip type)	
PART NO. GL10A-10R-12PA	REV. *
Linconn Etc Tech Co.,LTD	

由 Autodesk 教育版产品制作

由 Autodesk 教育版产品制作